

CARE-O-BOT-RESEARCH: PROVIDING ROBUST ROBOTICS HARDWARE TO AN OPEN SOURCE COMMUNITY

Dipl.-Ing. Florian Weißhardt

Fraunhofer Institute for Manufacturing Engineering and Automation IPA

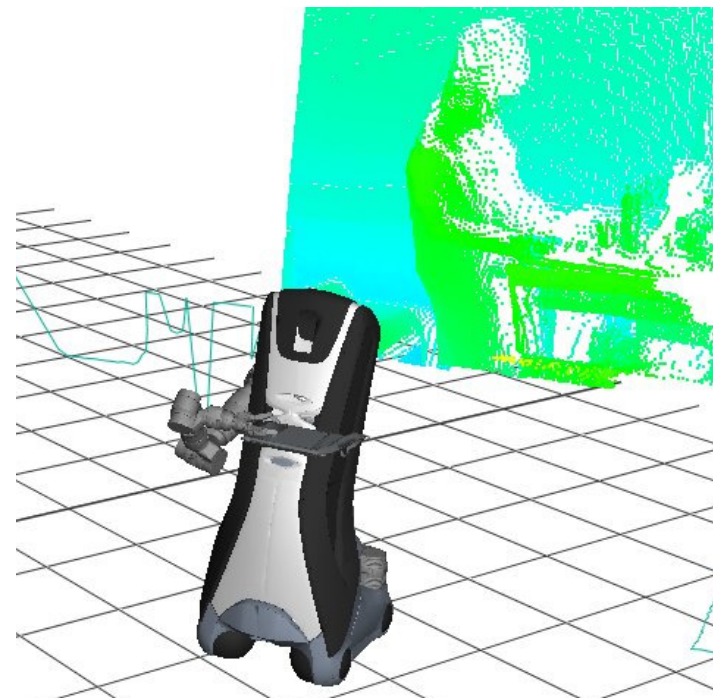
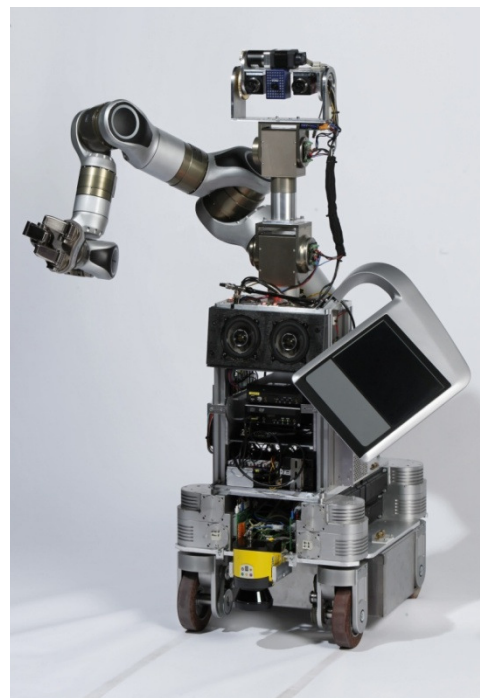

Outline

- Objective
- Care-O-bot[®] 3 platform
- Open source hardware drivers and simulation
- Remote access via web portal
- Conclusion and outlook

Common needs for research and development

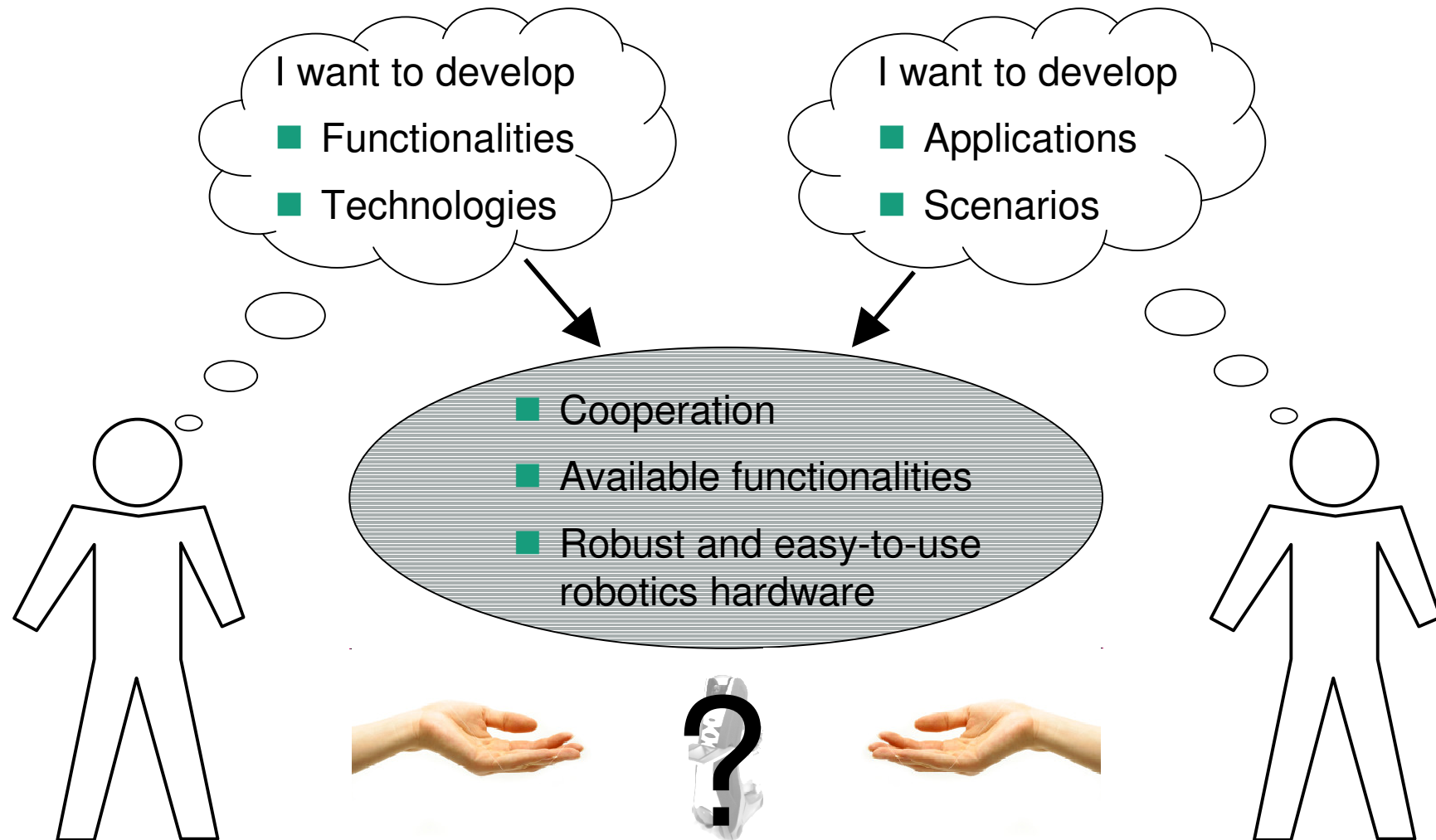

Providing Care-O-bot® 3 for different user groups

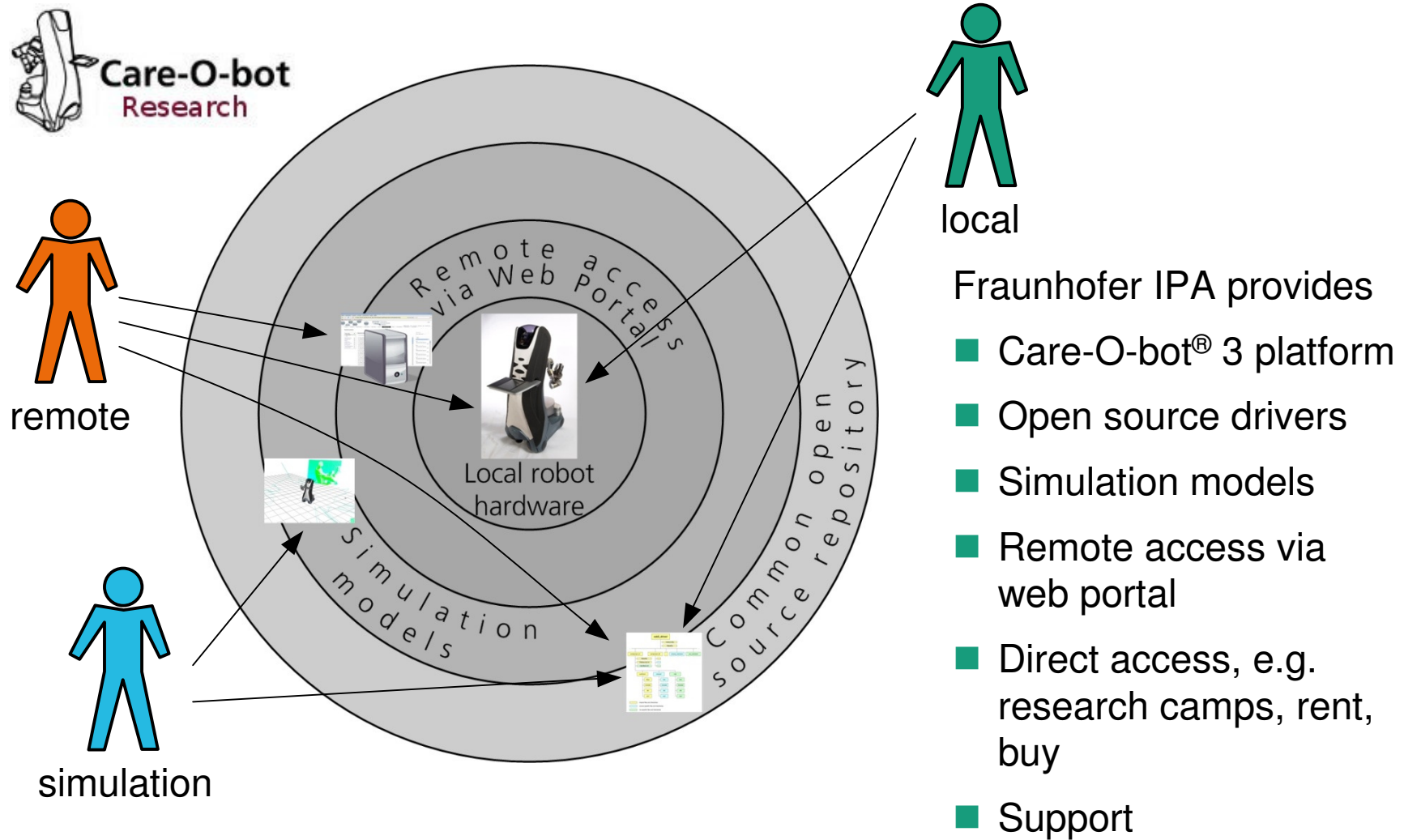

Outline

- Objective
- Care-O-bot[®] 3 platform
- Open source hardware drivers and simulation
- Remote access via web portal
- Conclusion and outlook

Care-O-bot[®] 3 mobile manipulation platform

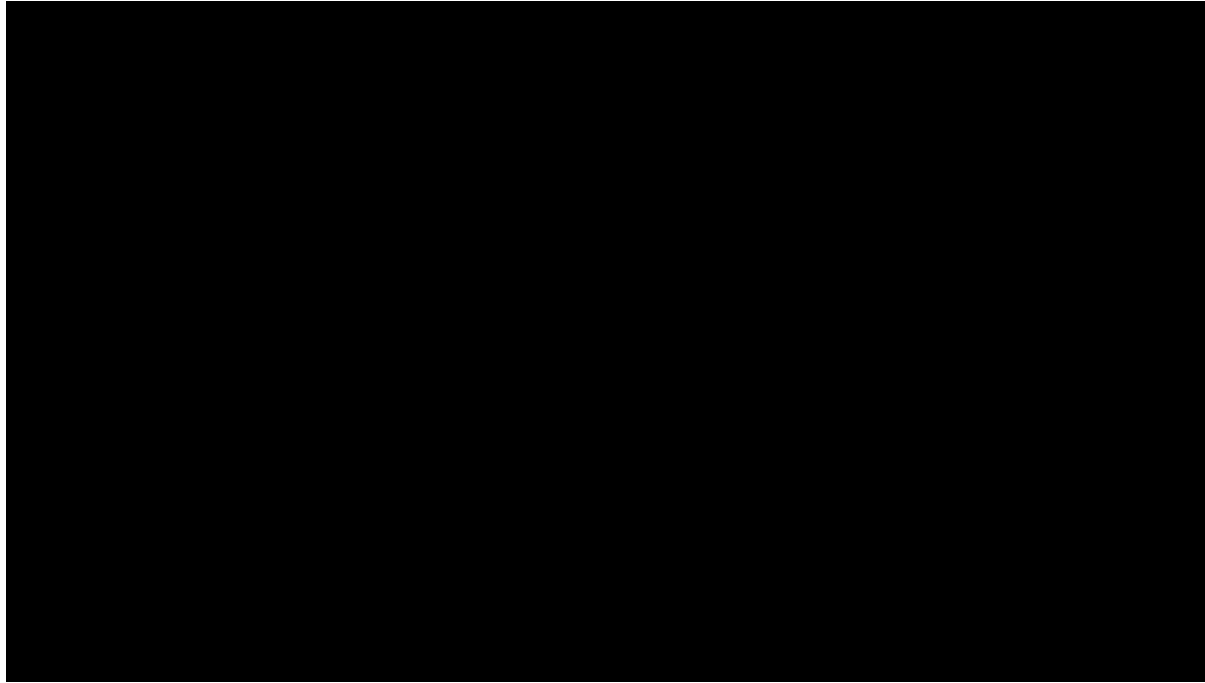

- Product vision, realized in 2008
- Functional design
- Two-side interaction concept
- Industrial grade components
- Reliable, robust and capable
- Compact integration
- Flexible system layout
- Easily extensible



Industrial grade hardware components

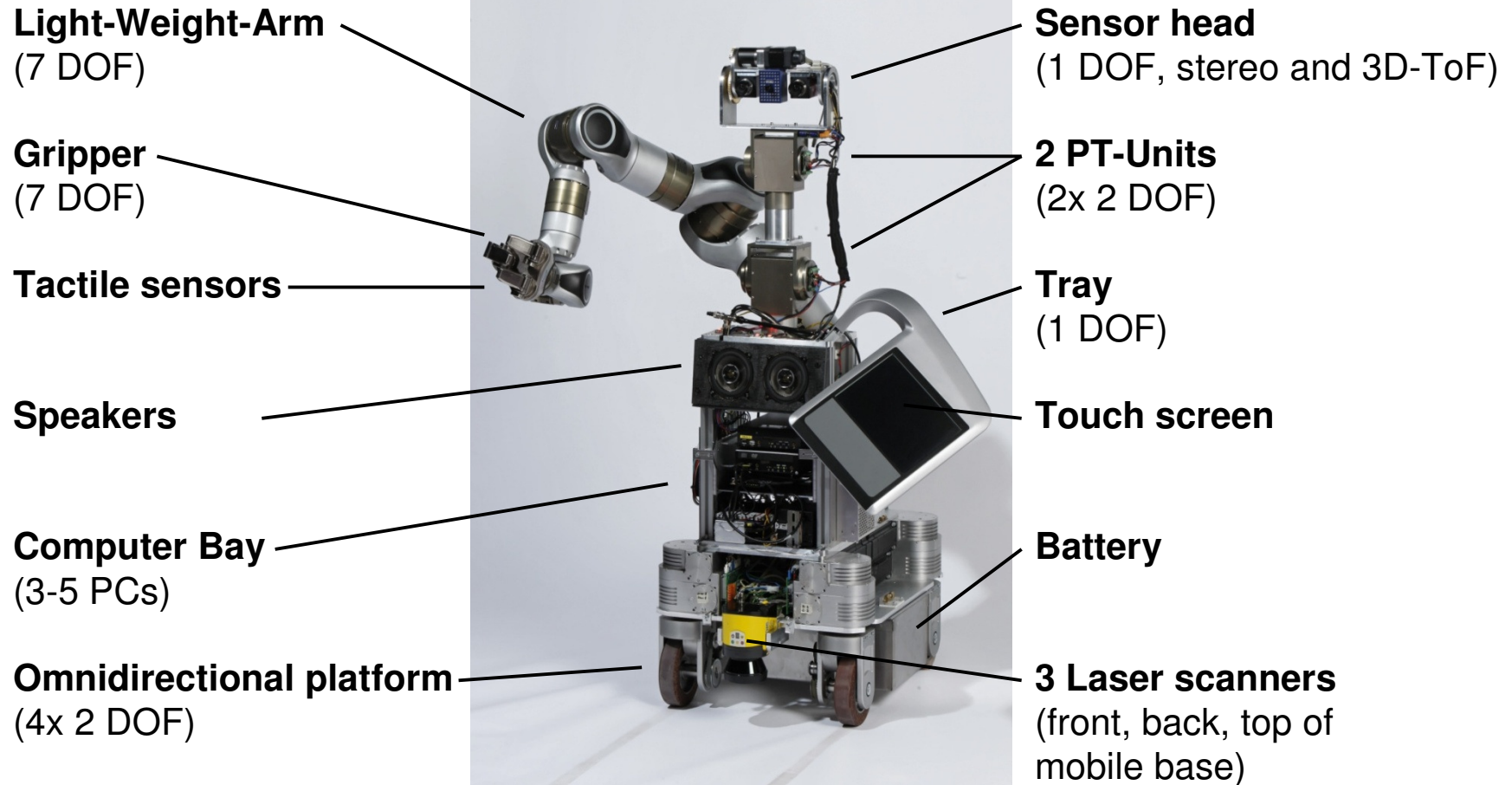

Flexible casing

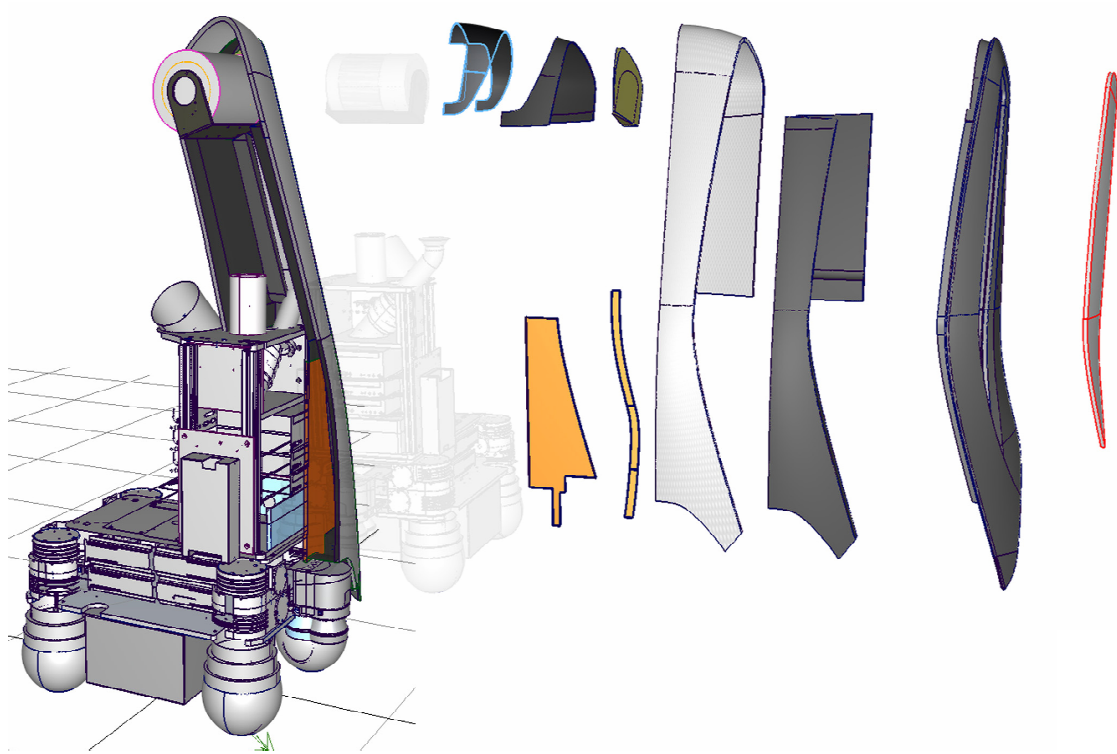

- For demonstration purposes or user studies
- Attractive and product like

Outline

- Objective
- Care-O-bot® 3 platform
- Open source hardware drivers and simulation
- Remote access via web portal
- Conclusion and outlook

Layered architecture

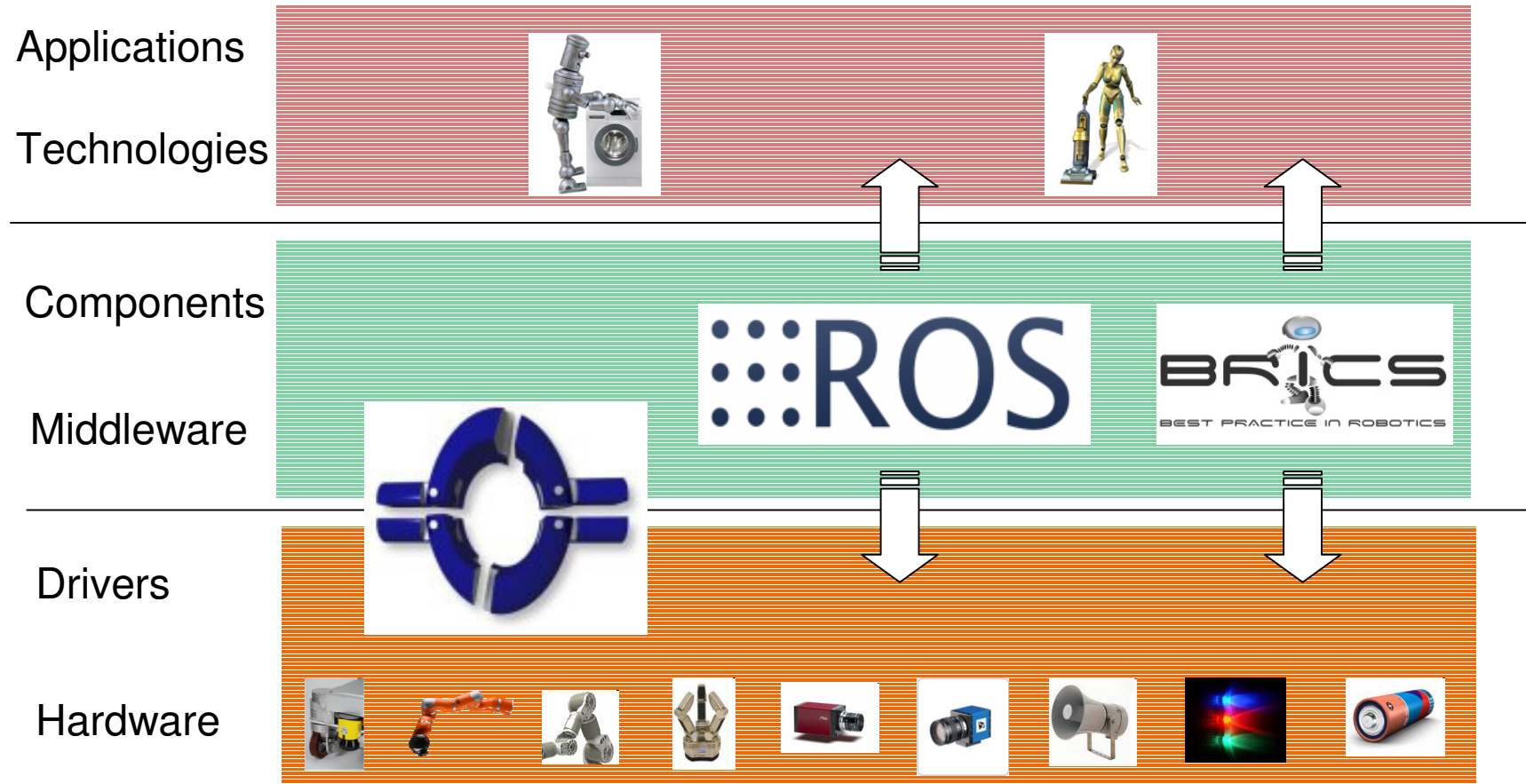

Extendable open source repository

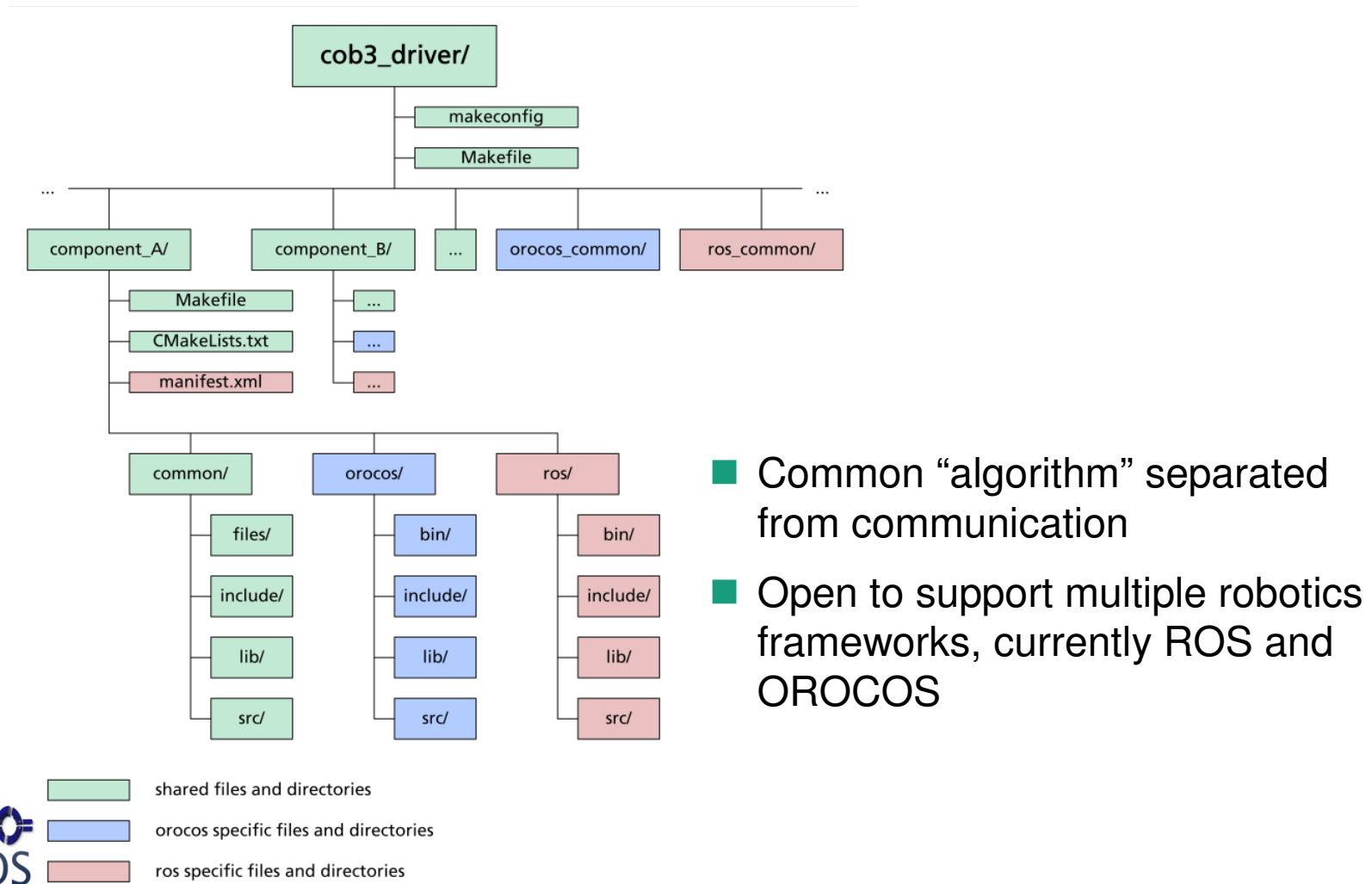

Integration of Care-O-bot[®] 3 drivers with ROS

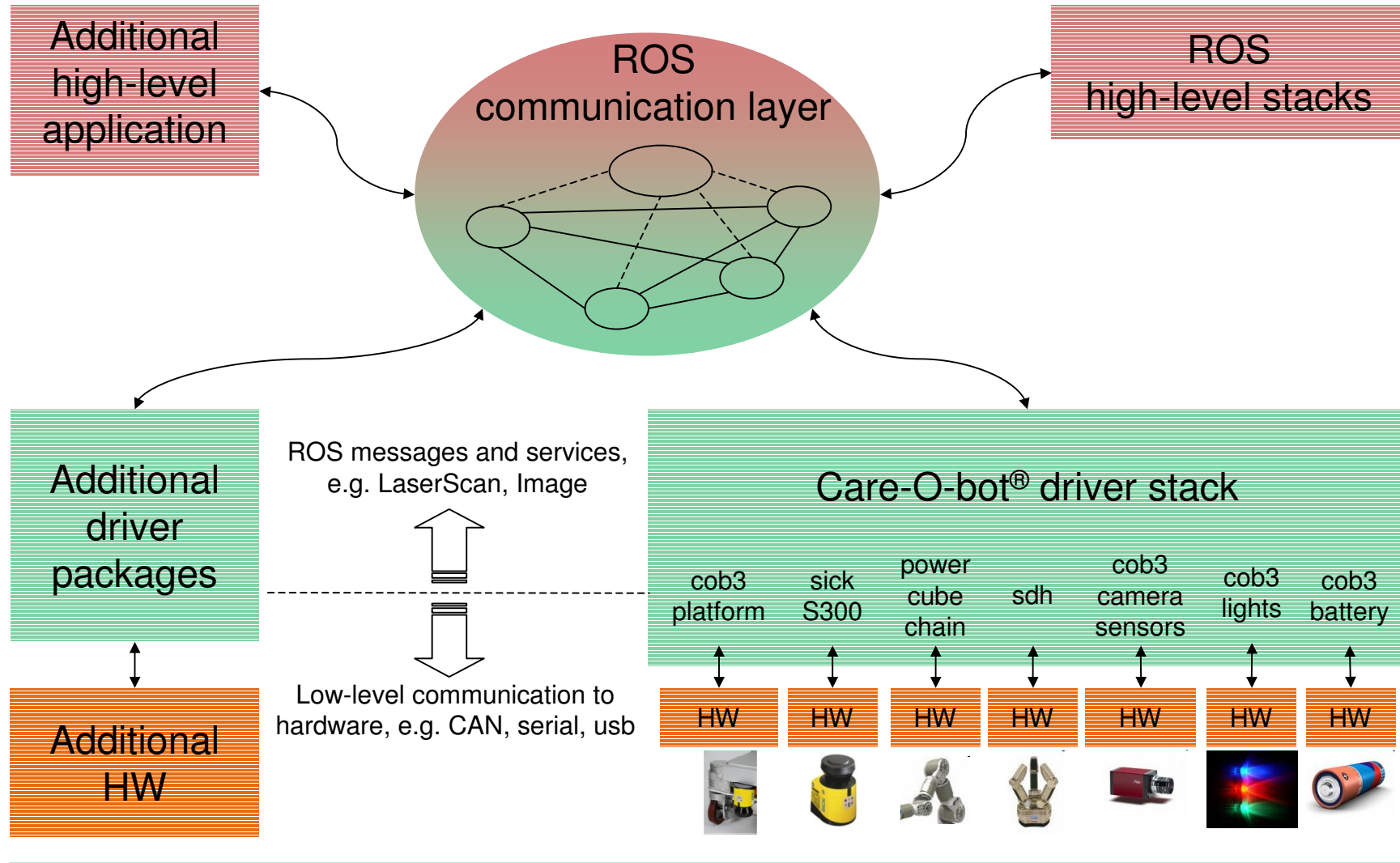

Multitude of built-in components and functionalities

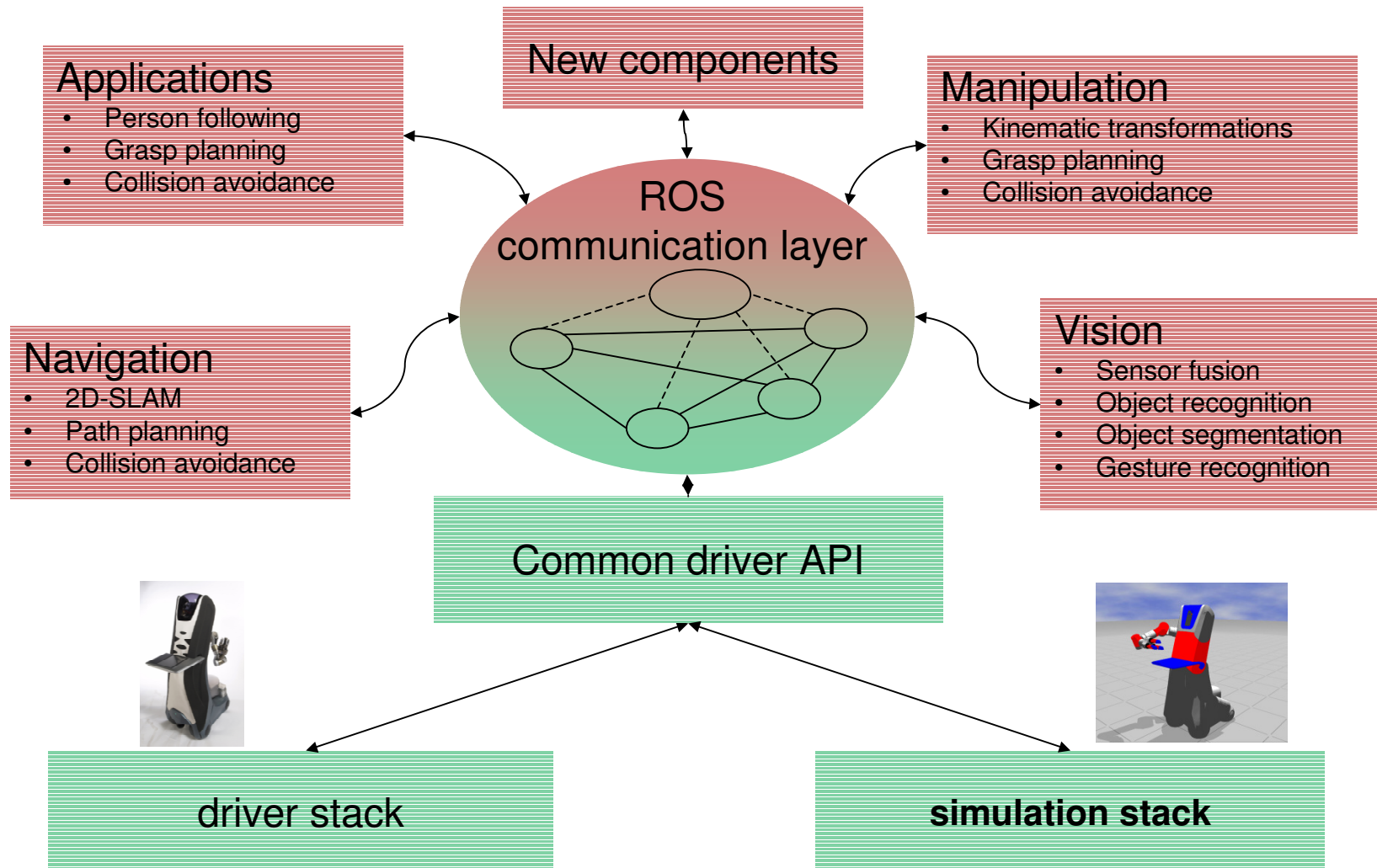

Simulation and visualization for realistic scenarios

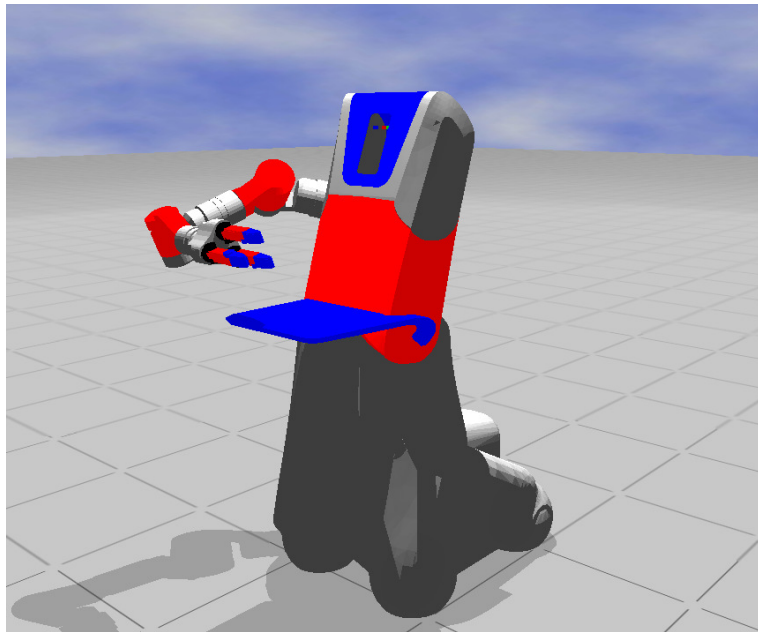
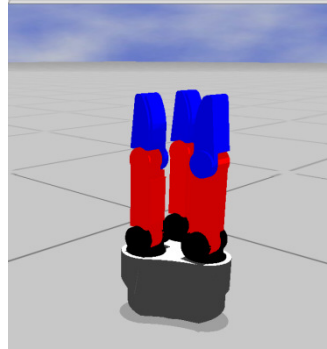
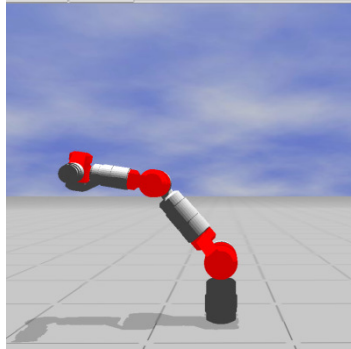

- Single simulated components
- Simulated sensors and actors, e.g.
 - Arm joints, hand
 - Cameras, laser scanners
- Model of the whole robot
- Kinematic and dynamic models of hardware components
- Environment modelling

Outline

- Objective
- Care-O-bot® 3 platform
- Open source hardware drivers and simulation
- Remote access via web portal
- Conclusion and outlook

Remote access via web portal

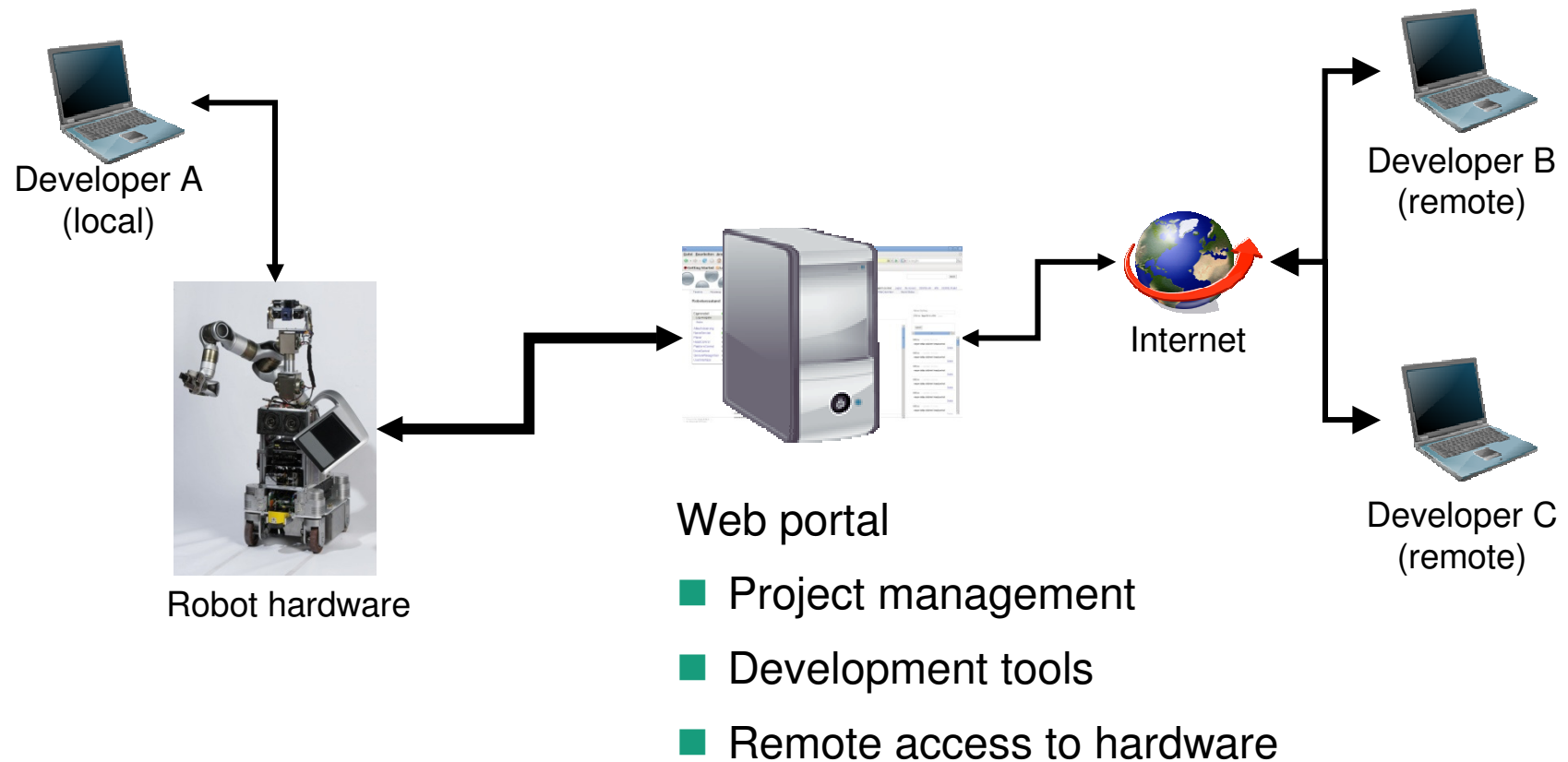

Sharing functionalities

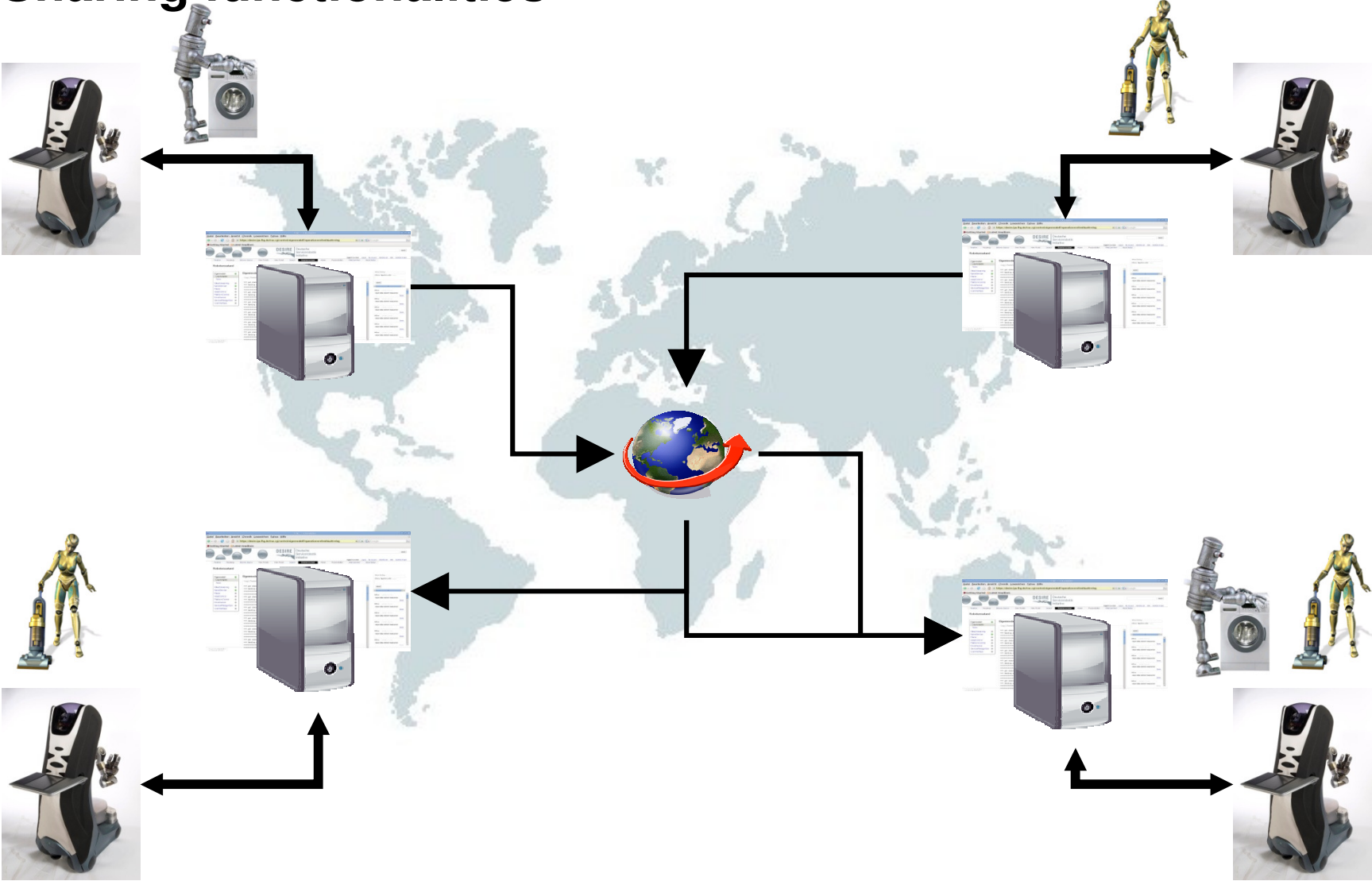

Outline

- Objective
- Care-O-bot® 3 platform
- Open source hardware drivers and simulation
- Remote access via web portal
- Conclusion and outlook

Conclusion

Focus on **your research topics** without caring about the hardware!

- The Care-O-bot® research initiative offers
 - Care-O-bot® 3 as a high-tech research platform
 - Reliable, robust and capable hardware
 - Remote access via web portal
 - Direct access, e.g. research camps
 - Rent or buy Care-O-bot® 3

■ Related R&D Projects

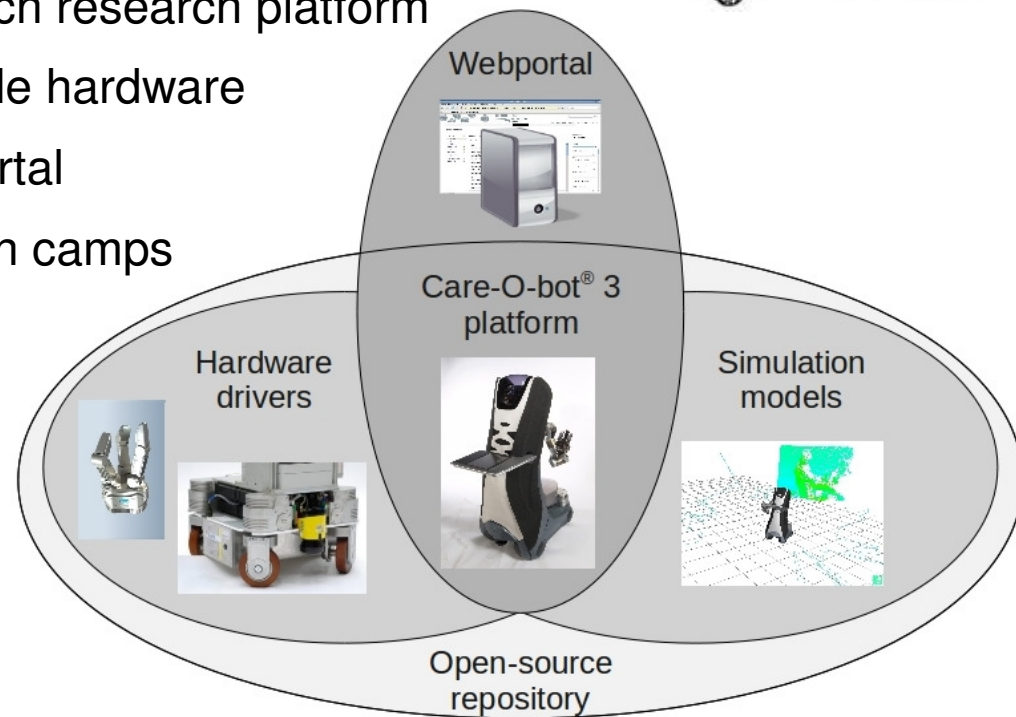

Thank you for your attention



www.care-o-bot-research.org
www.ros.org/wiki/care-o-bot

Contact:

Dipl.-Ing. Florian Weißhardt
Florian.Weisshardt@ipa.fraunhofer.de